



LOAD KING TRAILERS

Model 202 TT

P.O. Box 427
701 E. Rose ST.
Elk Point, S.D. 57025

Phone (605) 356-3301
Fax (605) 356-3268
Toll free (888) 264-5522
www.loadkingtrailers.com

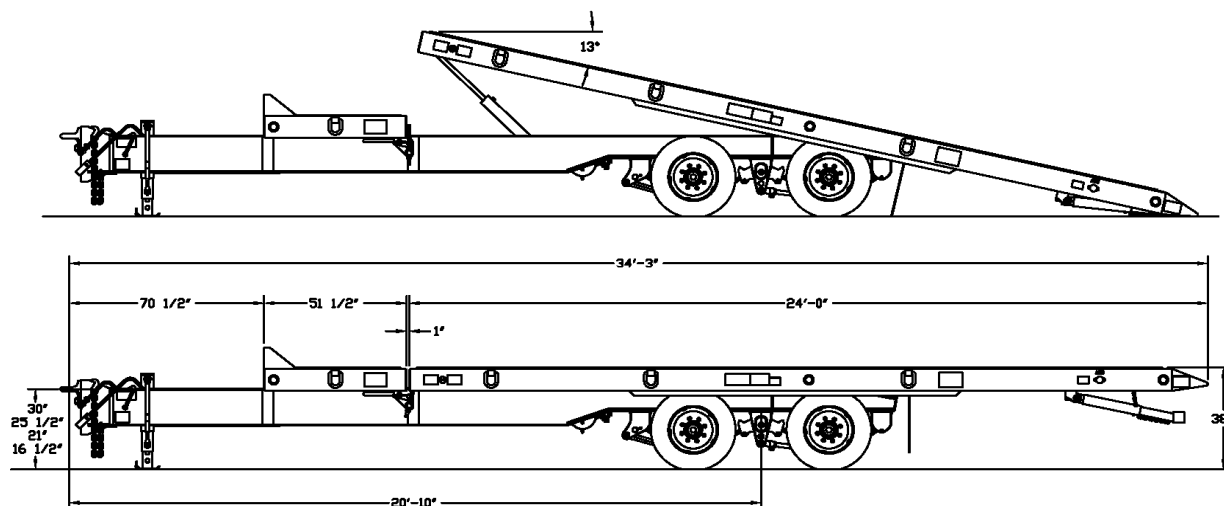

General Specifications

General description: 40,000 lb capacity tag-along trailer with tilting platform
Load capacity: 40,000 lb at 55 mph. (G.V.W.R. 48,400 lbs)
Overall length: 34'-0"
Deck length: 24'-0" tilting platform + 4" stationary platform
Tilting angle: 12 degrees
Deck width: 8'-6"
Deck height: 38" unloaded
Frame construction: Pierced main beam construction with one piece interlocking crossmember.
Mainbeams chassis: (2) W14" x 26lbs. Per ft., grade 50 Hi-tensile
Mainbeams tilt platform: (2) W8" x 15 lbs. per ft., grade 50 Hi-tensile
Crossmembers tilt platform: S6" I-beam x 12 1/2 lbs. per ft. grade 50 Hi-tensile on 22" centers
Siderails: C8" x 13.75 lbs. per ft. grade 50 Hi-tensile
Underride protection: Meets "National Highway Traffic Safety Administration" mandates FMVSS-223 & FMVSS-224
Headboard: 8" x 3" rectangular tube, full width of trailer

Decking: 2" nominal oak secured to crossmembers with 5/16" torque screws
Suspension: Hutch 9700 multi-point spring with radius rod axle tracking adjustment. 44,000 lb capacity
Axle: (2) Dexter 22,500 lb capacity with oil bath hubs.
Brakes: 12 1/4 "x 7 1/2" air brakes with "Wabco" anti-lock braking system and spring parking brakes
Wheels: 8 hole steel disc Hub-piloted Budd wheels
Tires: (8) 215/75R17.5, (H)
Parking jack: 12,000 lb dropleg, side crank
Hitch: 4 position cast steel pintle eye, 1-5/8" stock, 3" I.D.
Tie downs: Heavy duty D-rings, 3 per side
Safety chains: (2) 1/2" plated Hi-test
Cushioning cylinder: (1) 3 1/2" bore x 28" stroke internal flow hydraulic
Deck safety latch: Cantilever/U-bolt style, positive rattle free
Safety chains: (2) 1/2" plated Hi-test
Lights: 12 volt DOT & ICC approved. All lights are sealed beam type and flush mounted in rubber grommets. Wiring is run in flexible neoprene jacket and modular in design for ease of maintenance. 7 way plug.
Paint: Shot blast – primed and painted Load King Yellow