



LOAD KING TRAILERS

Model 2060-40-3

P.O. Box 427
701 E. Rose ST.
Elk Point, S.D. 57025
USA

Phone (605) 356-3301
Fax (605) 356-3268
Toll free (888) 264-5522
www.loadkingtrailers.com

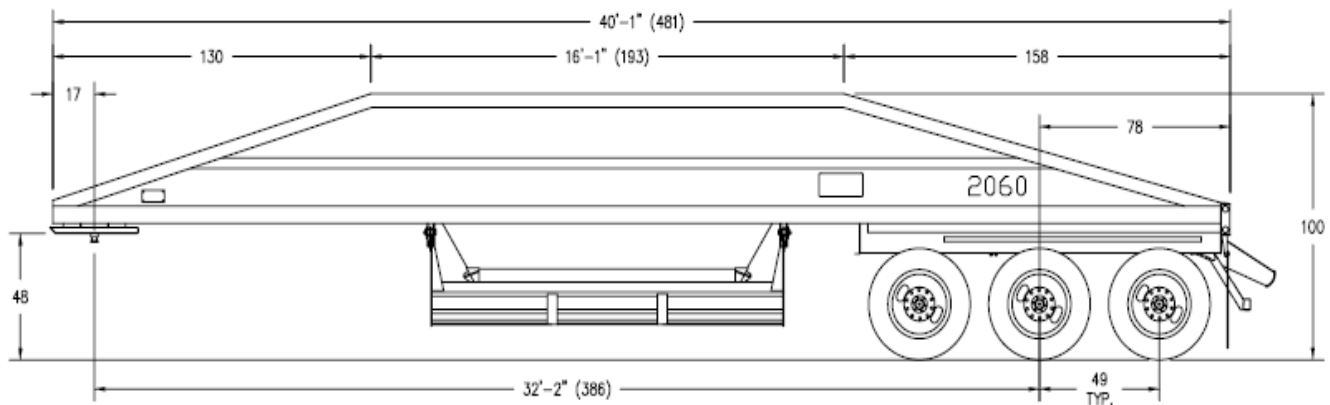

General Specifications

Dimensions

- 20 cubic yards struck capacity
- 60,000 lbs rated net payload
- 15,400 lbs estimated base trailer weight
- 40 foot overall length, 102 inch overall width
- 105 inch overall height
- 64 inch x 106 inch hopper dump opening
- 90" x 187" upper hopper opening
- 48 inch 5th wheel height

Frame

- 100,000/80,000 steel construction
- Boxed top rail to prevent material build-up
- Gate end tubular landing legs
- Replaceable gate pivot bearings
- Multiple positions flexi-set gate limiter
- 8 inch diameter gate cylinder with chromed tube and rod
- 12V solenoid operated gate controls
- Access center for gate air components
- Holes in gate ends for chain stops
- Rubber anti-spray / anti-sail-mud flaps with center cover
- Corner castings at lower hopper corners

Subframe

- 6 spring suspension with heavy duty multi-leaf springs
- 49 inch axle spacing
- Windrow deflector on front axle
- Three 22,500 lb axle capacity
- Twelve 11 R 22.5 tires
- 12 outboard mount hub piloted budd type disc wheels
- Timken tapered roller wheel bearings
- Stemco wheel seals with grit guard
- Rubber bushed side oscillating 5th wheel
- Oil seals
- 16 1/2 inch x 7 inch spring brake with ABS system external air drain

Other

- DOT rubber mounted sealed beam lights with modular harness
- Terex Load King mud flaps
- Shot blast – primed and painted Load King Yellow poly
- Hand Operated air valve
- Switch and wiring for in cab control

ALL WEIGHTS ARE +/- 3%