



LOAD KING TRAILERS

Model 253 TT

P.O. Box 427
701 E. Rose ST.
Elk Point, S.D. 57025
USA

Phone (605) 356-3301
Fax (605) 356-3268
Toll free (888) 264-5522
www.loadkingtrailers.com

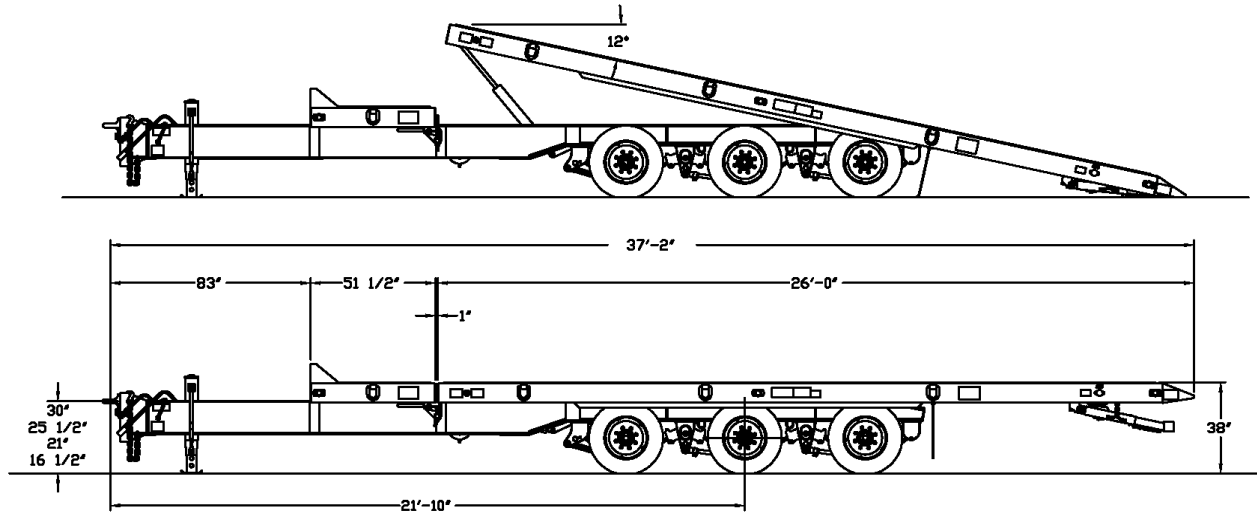

General Specifications

General description: 50,000 lb. capacity tag-along trailer with tilting platform

Load capacity: 50,000 lbs. at 55 MPH.
(G.V.W.R. 63,500 lbs.)

Overall length: 37'-2"

Deck length: 26'-0" tilting platform, 4'-0" stationary platform

Tilting angle: 12 degrees

Deck width: 8'-6"

Deck height: 38" unloaded

Frame construction: Pierced main beam construction with one piece interlocking crossmember.

Mainbeams chassis: (2) W14" x 26lbs. per ft., grade 50 Hi-tensile

Mainbeams tilt platform: (2) W8" x 15 lbs. per ft., grade 50 Hi-tensile

Crossmembers tilt platform: S6" I-beam x 12 1/2 lbs. per ft. grade 50 Hi-tensile on 22" centers

Siderails: C8" x 18.75 lbs. per ft. grade 50 Hi-tensile

Underride protection: Meets "National Highway Traffic Safety Administration" mandates FMVSS-223 & FMVSS-224

Headboard: 8" channel, full width of trailer

Decking: 2" nominal oak secured to crossmembers with 5/16" torque screws

Suspension: Hutch 9700 multi-point spring with radius rod axle tracking adjustment. 44,000 lb capacity

Axle: (2) Dexter 22,500 lb capacity with oil bath hubs.

Brakes: 12 1/4 "x 7 1/2" air brakes with "Wabco" anti-lock braking system and springs parking brakes

Wheels: 8 hole hub piloted steel disc

Tires: (12) 235/75R17.5, (H)

Landing gear: 2 speed landing leg

Hitch: 4 position cast steel pintle eye, 1-5/8" stock, 3" I.D.

Tie downs: Heavy duty D-rings, 3 per side

Cushioning cylinder: (1) 3 1/2" bore x 28" stroke internal flow hydraulic

Deck safety latch: Cantilever/U-bolt style, positive rattle free

Lights: 12 volt DOT & ICC approved. All lights are sealed beam type and flush mounted in rubber grommets. Wiring is run in flexible neoprene jacket and modular in design for ease of maintenance. 7 way plug.

Paint: Shot blast – primed and painted Load King Yellow