



# LOAD KING TRAILERS

## Model 402/604 DD MB

P.O. Box 427  
701 E. Rose ST.  
Elk Point, S.D. 57025  
USA

Phone (605) 356-3301  
Fax (605) 356-3268  
Toll free (888) 264-5522  
[www.loadkingtrailers.com](http://www.loadkingtrailers.com)

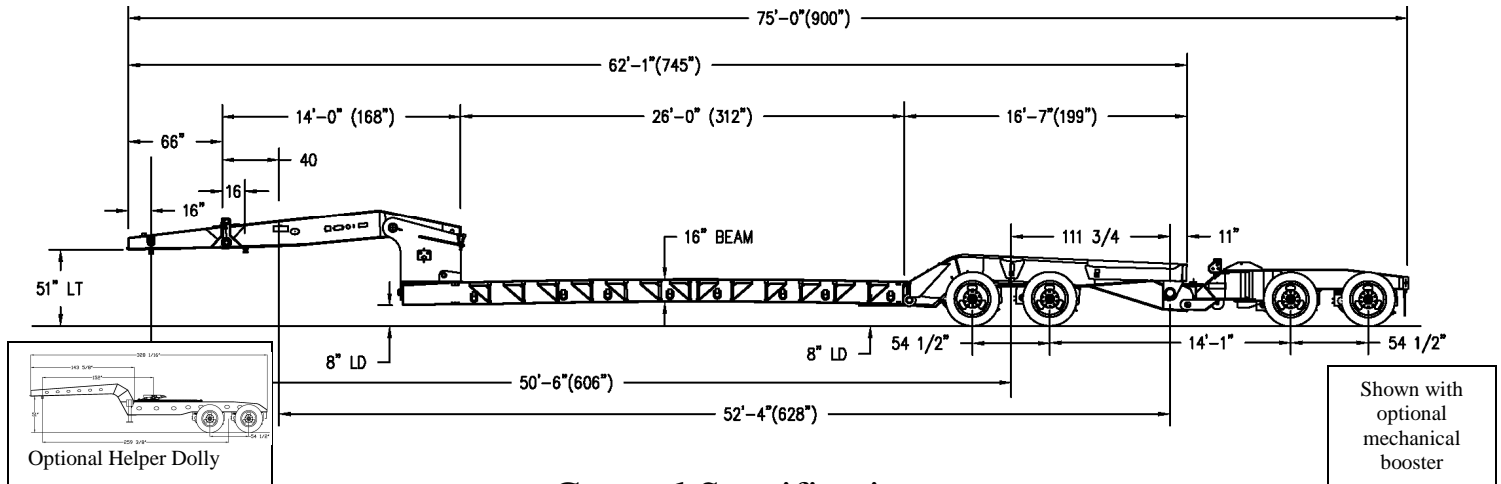

### General Specifications

#### Dimensions:

- 40 tons in 12' load concentration with 2 axles @ 60 mph
- 60 tons in 12' load concentration with 4 axles @ 60 mph
- 100,000/80,000 psi yield strength steel
- 29,700# estimated base weight
- 19'-6" gooseneck length including 66" flip over extension
- 175" swing clearance with 109" & 85" swing on base
- Gooseneck
- 26' deck length
- 102" wide
- 24" loaded deck height
- 8" loaded ground clearance
- 51" 5<sup>th</sup> wheel height

#### Gooseneck:

- Hydraulic Non-ground bearing gooseneck design
- Ratchet system enables multiple ride heights
- Hydraulic frame lift support
- Hydraulic pressure to kingpin load chart
- Air activated self locking pin design
- Gooseneck controls located at rear of gooseneck on drivers Side
- Wet kit operation, less tractor portion

#### Deck:

- 4 full depth 16" cambered deck beams
- 30" front flip ramps
- Heavy duty I-beam Crossmembers on 24" centers
- 8 D-rings per side
- 26 full depth fabricated outriggers-powder coat finish

#### Deck Continued:

- 2" Apatong in track area secured with bolts, clips, and screws
- 30 degree radius rear drop
- 3/4 height rear bolster
- Deck to subframe connection: removable with horizontal pin

#### Subframe:

- Two (2) fixed 25,000 lb axles
- Inner subframe suspension beams and connections for optional 2<sup>nd</sup> axel mechanical booster
- Air ride suspension with auto and adjustable height control
- 54 1/2" axle spacing
- Eight (8) 275/70R22.5 16 pr radials
- Hub piloted steel disc wheels
- Outboard mounted drums
- 16 1/2" X 7" brakes
- Spring brakes on 1 axle
- Excavator cutout – open to tailgate
- Wheel boxes between axles

#### Other:

- DOT rubber mounted sealed beam lights with modular Harness
- Load King mud flaps
- Shot blast – primed and painted Black polyurethane

#### Compatibility:

- Helper dolly: HD702G
- MB502

#### Operating Pressure/GPM

Wet kit System requires 3000 PSI at 10 GPM  
Maximum flow to lift load at full capacity  
ALL WEIGHTS ARE +/- 3%