



LOAD KING TRAILERS

Model 503/554 DD MB

P.O. Box 427
701 E. Rose ST.
Elk Point, S.D. 57025
USA

Phone (605) 356-3301
Fax (605) 356-3268
Toll free (888) 264-5522
www.loadingtrailers.com

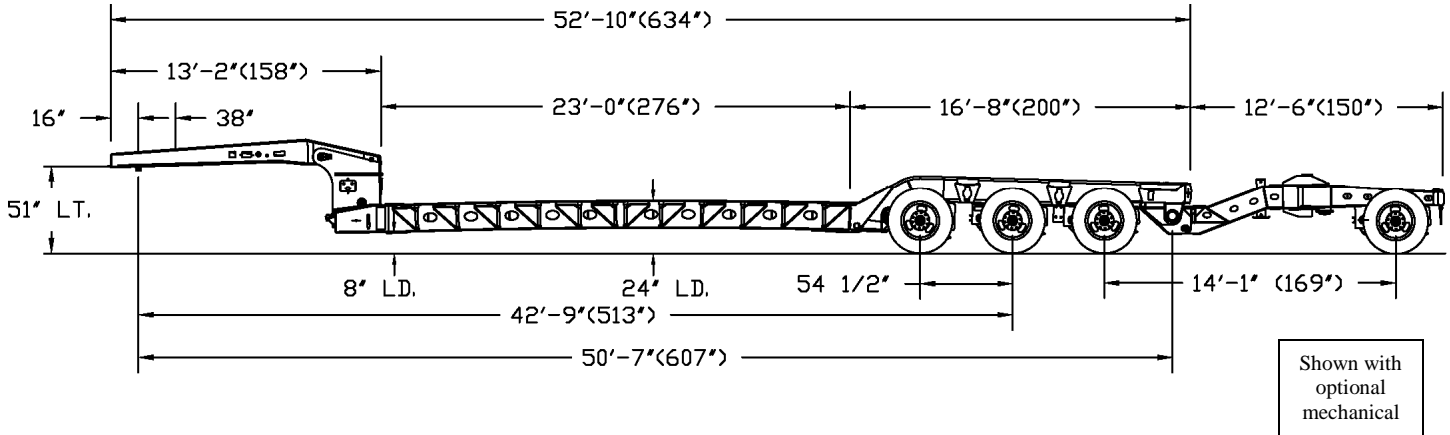

General Specifications

Dimensions:

- 100,000lb capacity three axles, 110,000lb with booster in 12 foot load concentration @ 60 mph
- 100,000/80,000 psi yield strength steel construction
- 25,800lb estimated base unit weight
- 13'-2" gooseneck length
- 114" & 92" swing clearance
- 23' deck length, 102" deck width
- 24" loaded deck height
- 8" loaded ground clearance

Gooseneck:

- Wet kit operation, less tractor portion
- Non-ground bearing removable
- Expanded metal last 8 foot of deck for storage
- Air operated self locking gooseneck lock

Deck:

- Cambered with full depth 16 inch deck beams
- Heavy duty I-beam Crossmembers
- 30" front flip up ramps
- 7 lashing bars on each side of deck
- 2 inch Apitong full width
- Removable deck to subframe connection

Subframe:

- Air ride suspension with auto and manual controls
 - 1st axle mounted direct to trailer frame
 - 1st axle air lift
 - 54 1/2" axle spacing
 - Spring brakes
 - 275/70R 22.5 tires (on all)
 - Hub piloted bud type disc wheels
 - 16 1/2" X 7" brakes
 - Oil seals
 - Inner subframe suspension beams and connections for optional single axle mechanical booster
- NOTE:** 1st axle mounted directly to trailer main frame

Other:

- DOT rubber mounted sealed beam lights with modular Harness
- Load King mud flaps
- Shot blast – primed and painted Black polyurethane

Compatibility:

- Helper dolly: None
- Mechanical booster: MB251

Operating Pressure/GPM
Wet kit System requires 3000 PSI at 10 GPM
Maximum flow to lift load at full capacity
ALL WEIGHTS ARE +/- 3%