



LOAD KING TRAILERS

Model 503/604 SS SF

P.O. Box 427
701 E. Rose ST.
Elk Point, S.D. 57025
USA

Phone (605) 356-3301
Fax (605) 356-3268
Toll free (888) 264-5522
www.loadkingtrailers.com

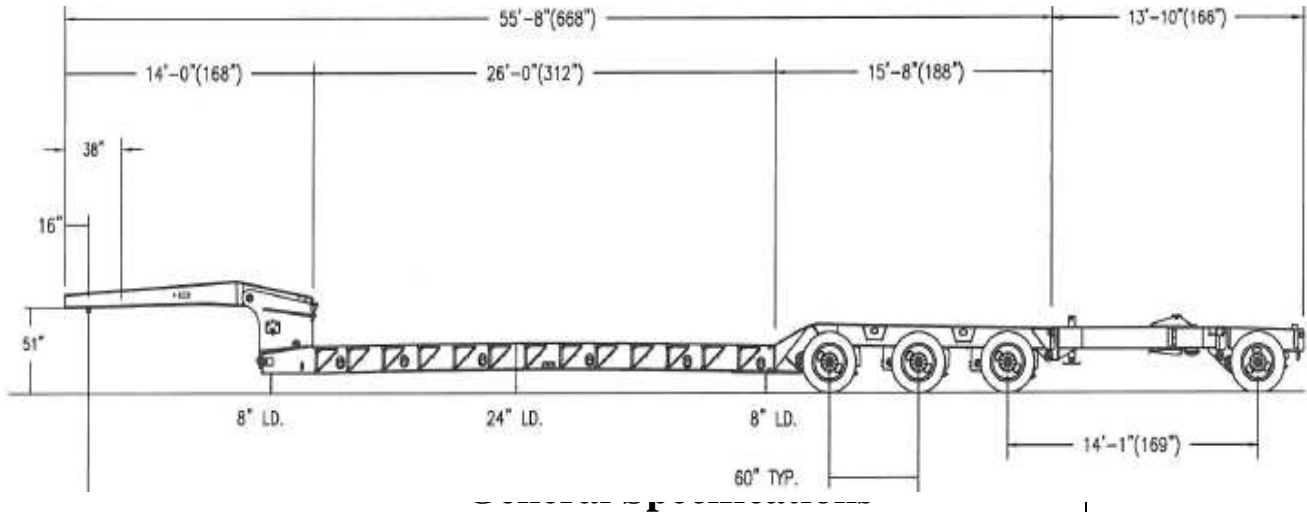

Shown with optional
stinger flip

Dimensions

100,000 lb capacity on 3 axles, 120,000 lb with
stinger/flip 12 ft. load concentration @ 60 mph
100,000 / 80,000 psi yield strength steel
construction
24,500 lb estimated base unit weight
14 ft. 0 in. gooseneck length
115 in. and 93 in. swing clearance
26 ft. deck length, 102 in. deck width
24 in. loaded deck height
8 in. loaded ground clearance

Gooseneck

Wet kit operation, less tractor portion¹
Non-ground bearing removable
Air operated self locking gooseneck lock

Deck

Cambered with full depth 16 in. deck beams
Heavy duty I-beam crossmembers
31 in. front flip up ramps
6 D-rings on each side of deck + 1 rear subframe
2 in. Apitong track area only
Swing out outriggers (boards not included)
Fixed / welded deck to subframe connection

Subframe

Air ride suspension with auto & manual control
Connection for optional 4th axle & spreader bar
60 in. axle spacing
Spring brakes on axles 1 & 2
275/70 R 22.5 tires (on all)
Hub piloted steel disc wheels
16½ x 7 brakes
Oil seals
Lowered last 3 crossmembers between main
beams with 3/8 in. plate

Other

DOT rubber-mounted sealed LED lights with
modular harness
Shot blast-prime and paint with black poly
Red and white conspicuity striping

Compatibility

Helper dolly : none
FL201 SF and SB 141 (required for 60 ton rating)

Operating Pressure/GPM

Wet kit System requires 3000 PSI at 10 GPM
Maximum flow to lift load at full capacity
ALL WEIGHTS ARE +/- 3%

“Specifications subject to change without notice, drawing may show optional equipment.”

Rev 100117